

IMAGE CONCEPT

# RÉVÉLER LA SOUFFLERIE ET LE HANGAR AV À MEUDON

## ONERA un site enclavé

3 propriétaires

35 hectares

16 hectares de l'ONERA

6 hectares du lycée

12,5 hectares du Ministère de la Culture

2 monuments classés historiques

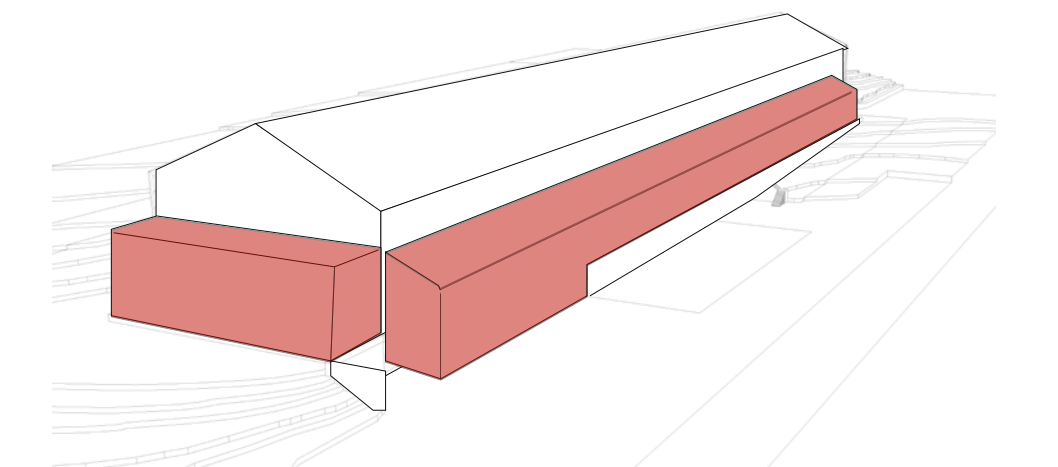

ÉLÉMENTS NON CONSERVÉS DU HANGAR AV

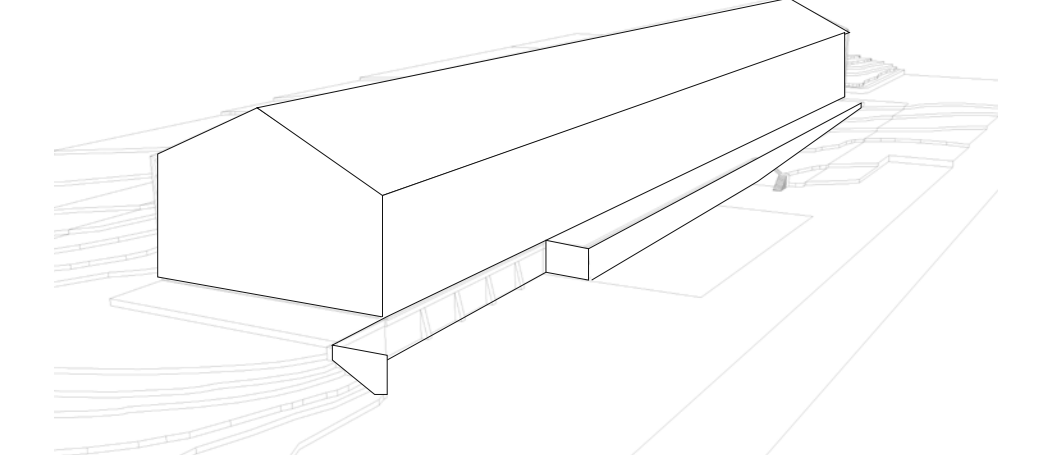

ÉLÉMENTS CONSERVÉS DU HANGAR AV



SON PATRIMOINE

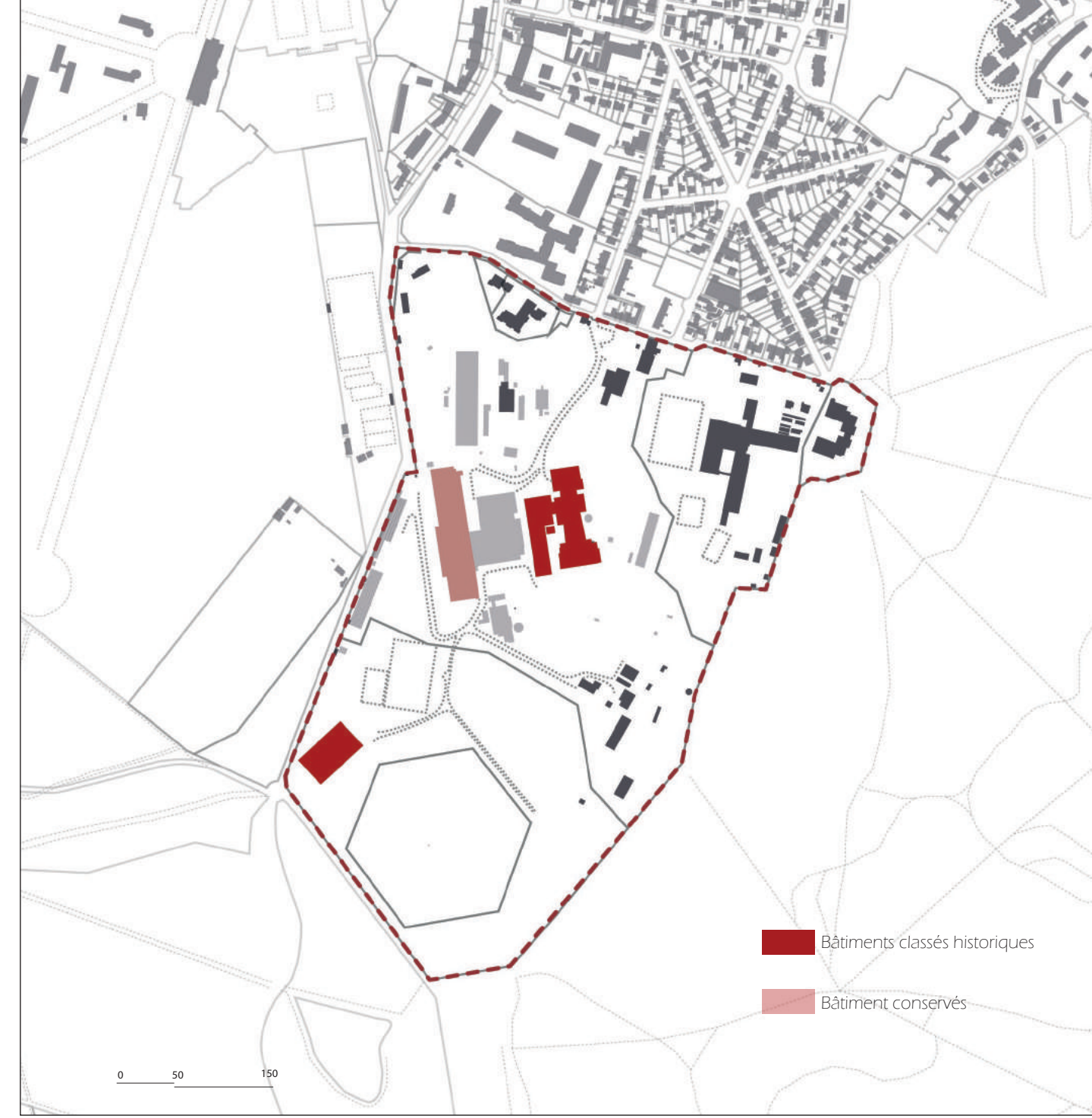

BATIS CONSERVÉS



PLAN ACTUEL



PROJET URBAIN



PLAN R+1 1:250e

HALLE DE CONSTRUCTION	halle d'exposition	1 200 m <sup>2</sup>
	halle de construction	2 200 m <sup>2</sup>
	ateliers	200 m <sup>2</sup>
	aire de livraison et de stockage	150 m <sup>2</sup>
	atelier de tri et de stockage	500 m <sup>2</sup>
ESPACES PÉDAGOGIQUES	salles de classes	1 200 m <sup>2</sup>
	salles de travail	200 m <sup>2</sup>
	salles de polyvalente	800 m <sup>2</sup>
	amphithéâtre / salle de conférence	500 m <sup>2</sup>
	hall accueil	120 m <sup>2</sup>
ESPACE D'ÉCHANGE	administration	300 m <sup>2</sup>
	bibliothèque	800 m <sup>2</sup>
	caféteria	400 m <sup>2</sup>
	locaux techniques / WC / infirmerie	150 m <sup>2</sup>
total		8 720 m <sup>2</sup>

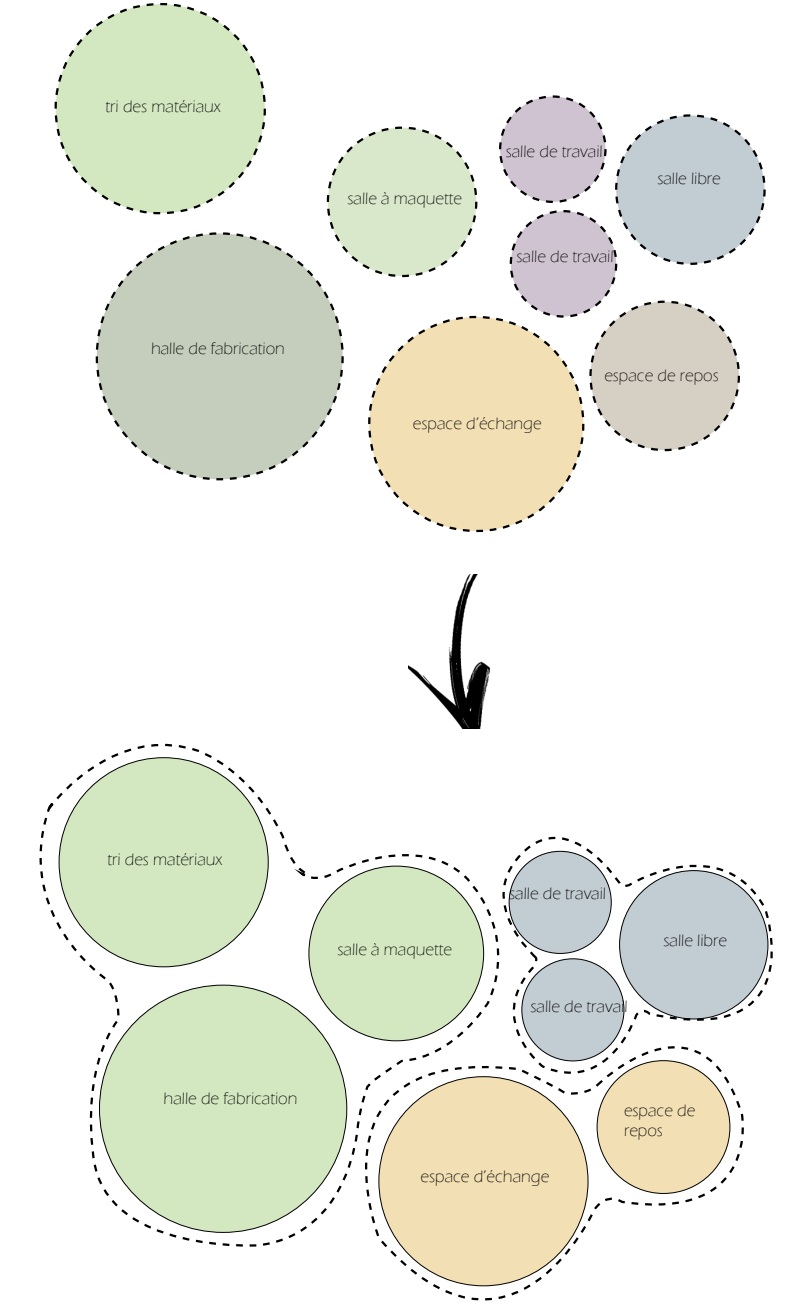

VUE DU HANGAR AV

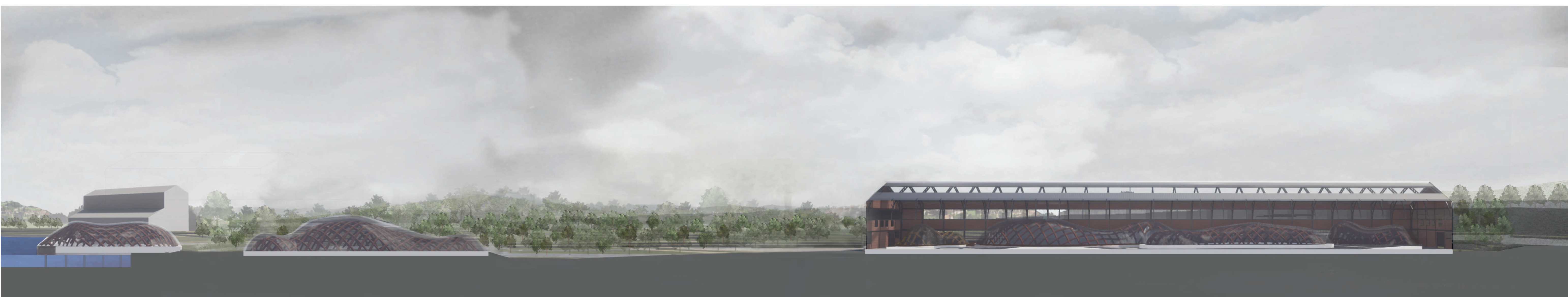

COUPE LONGITUDINALE 1:250e